

GLOBAL LIFT CORP



Owner's Manual

Superior Series



684 N Port Crescent Rd
Suite C

Bad Axe, MI 48413

Toll Free: 866-712-0606

Fax: 989-269-5902

www.globalliftcorp.com



SUPERIOR AND PROFORMANCE SERIES POOL LIFTS

TABLE OF CONTENTS

INTRODUCTION	PAGE – 3
ADA GUIDELINES FOR PLACEMENT	PAGE – 4
24 VOLT BATTERY SYSTEM/WITH CONTROLS	PAGE – 5
SUPERIOR SERIES OPERATING INSTRUCTIONS	PAGE – 6
UNIT MAINTENANCE AND CARE	PAGE – 7
TROUBLESHOOTING	PAGE – 8
WARRANTY INFORMATION	PAGE – 9/10/11
WARRANTY REGISTRATION	PAGE - 12
NEW CONSTRUCTION ANCHOR INSTALLATION	
RETRO FIT ANCHOR INSTALLATION	
FIXED ANCHOR INSTALLATION	
OPTIONAL FIXED DROP IN ANCHOR INSTALLATION	
SEAT INSTALLATION INSTRUCTIONS	



INTRODUCTION

Your Number One Choice for Commercial Pool Access Equipment

Global Lift Corp. is located in Mid Michigan, Global Lift Corp. prides itself in manufacturing top of line quality aquatic access equipment. Global Lift Corp.'s key staff has a century of combined industry experience and we take pride in each and every product that we build. Our Company is ISO Certified and our products are manufactured in the United States. Global Lift Corp uses only the finest materials and processes to provide our customers with the highest quality products while still maintaining a price competitive edge.

ADA GUIDELINES FOR POOL LIFT PLACEMENT

1. Pool Lift Location. Pool lifts shall be located where the water level does not exceed 48 inches (1220 mm).
2. Seat Location. In the raised position, the centerline of the seat shall be located over the deck and 16 inches (405 mm) minimum from the edge of the pool. The deck surface between the centerline of the seat and the pool edge shall have a slope not steeper than 1:48.

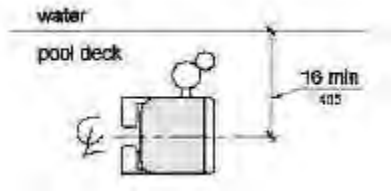

3. Clear Deck Space. On the side of the seat opposite the water, a clear deck space shall be provided parallel with the seat. The space shall be 36 inches (915 mm) wide minimum and shall extend forward 48 inches (1220 mm) minimum from a line located 12 inches (305 mm) behind the rear edge of the seat. The clear deck space shall have a slope not steeper than 1:48.

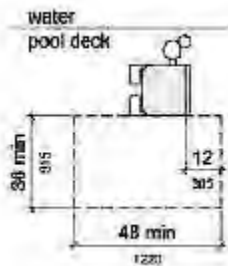

4. Submerged Depth. The lift shall be designed so that the seat will submerge to a water depth of 18 inches (455 mm) minimum below the stationary water level. To make sure the lift has enough clearance the lift should be installed at a location **with 48"** of Water depth

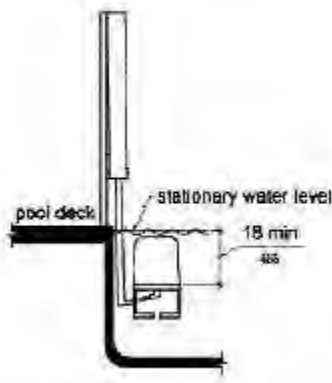

24 VOLT BATTERY SYSTEMS WITH CONTROLS

All of Global Lift Corp's Superior/Proformance Series Lifts are equipped with a sealed 24 volt battery that is rechargeable. Along with a charging unit, hand held controller and control compartment. The 24 volt battery mounts right above the control compartment and the battery simply snaps in. The battery should be charged for 5-8 hours prior to the 1st use.

The unit is operated by the 2 button easy to use controls. Staff will use the provided key to unlock the lift. The lock feature is located on the hand controls or front of the control box. Insert the key provided and turn to unlock the unit for use. (Avoid turning the key farther than 45 degrees as it will damage the key) Once unlocked, the arrow pointing down will lower the lift when depressed, the arrow that points up will raise the unit when depressed. **If you hear the low battery indicator tone "Do Not Use the Lift"** remove the battery from the unit and recharge the battery.

RECHARGING THE BATTERY:

Remove battery from the unit by unclipping from the control compartment. When setting the battery down, place it horizontally as to avoid contacting the battery terminals with anything conductive, and damaging the battery. Place the rubber cover over the control box connectors. Place the battery in the charging unit. When the battery is charging the light will be illuminated red/orange, indicating charging. Once fully charged the charge light will turn green, indicating fully charged and ready for use in your Superior/Proformance series pool lift.



SUPERIOR SERIES POOL LIFT OPERATING INSTRUCTIONS

Prior to using the Superior/Proformance Series Pool Lift perform a test run of the lift empty. Once that is completed and the lift is back to original position, make sure that the arm lifts are in the up position and the seatbelt is unbuckled, once acknowledged you are ready!

Once you are in the seat, buckle the seatbelt (make sure it is snug) and lower the arm rails. Before you attempt to operate the lift, make sure the pathway is clear from any obstacles.

Once you have the 2 button easy controls in your hand, press the arrow that specifies **down, keep in mind you don't have to go to the bottom of the cycle, you can stop the lift** whenever you deem comfortable to exit the lift. However when exiting the pool while on the lift, you should complete the cycle back to the top to have a completely safe exit from the pool.

Once submerged into the pool, unbuckle the seatbelt and raise the armrest and slide off of the seat. Once you are done with your pool activity, make sure the seat is lowered sufficiently to allow you too easily slide back into the chair. Once you are seated, buckle the seatbelt and make sure that it is snug, lower the armrest.

Next, to raise the lift chair out of the pool, make sure you press the button/arrow that represents up on the control. Apply continuous pressure until the lift comes to a complete stop at the end of the complete up cycle on the deck. You now can unbuckle the seatbelt and raise the arm rest and exit the unit. Staff will turn the key on the hand control or front of the control panel to re-lock the lift when the pool is not in operation. In the unlikely event that the lift does not return from the water using the hand control, have an attendant press the emergency return button on the front of the control box or on the underside of the control box and the lift will return to pool side.



Maintenance

Regular servicing will help prolong the life of your lift. Routine maintenance and cleaning is very important. The following is a routine maintenance you should follow.

Daily

- Check and charge battery if needed
- Test for normal operations
- Inspect your lift
- Clean and dry the lift and seat with clean water
- Cover lift after use

Weekly

- Overview Daily Checklist
- Wipe away any surface rust with household spray cleaner
- Clean tough stains with Scotchbrite pad and wipe clean

Monthly

- Inspects all connections, frame, seat etc,
- Clean battery connections
- Clean metallic surfaces with wax cleaner

The maintenance provision of the ADA states that "a public accommodation shall maintain in operable working condition those features of facilities and equipment that are required to be readily accessible to and usable by persons with disabilities"



TROUBLESHOOTING GUIDE

Before any troubleshooting commences make sure the battery has a full charge!

(1) Does the lift raise or lower

NO

- (a) Check the battery connection and reconnect
- (b) Check hand controls, make sure they are connected properly
- (c) Check for any loose wires on the control compartment
- (d) Check the connection cable for damage
- (e) Check to see that the lock on the hand control or front control box is in the unlocked position.
- (f) Check to see if the battery has 24+ volts using a multimeter or volt meter

(2) Did the lift stop moving over water and is stuck?

Yes

- (a) Have a person or attendant push the emergency return button.
- (b) The button is located on the front of the main control box or on the underside of control box. The emergency button overrides the hand controls in case they have failed.
- (c) If the above does not work then recheck the battery, battery connection or the controls are not connected properly.



Global Lift Corp Warranty Information

The **Superior** series lift has a 5 year structural limited warranty. Global Lift Corp warrants to the original retail end user only products manufactured by Global Lift Corp, when properly installed in accordance to the assembly and installation instructions, and when the equipment is properly *used and maintained, to be free from material defects and workmanship as stated below:*

- Warranty starts from date of original purchase
- Metal structure (not including powder coat) 5 year limited structural warranty Actuator and controls – 2 years from date of purchase then 2 years prorated
- Actuator and controls – 3 years 50% coverage (Customer is responsible for 50% of replacement cost)
- Actuator and controls – 4 years 30% coverage (Customer is responsible for 70% of replacement cost)
- Battery – 1 year from date of purchase

*This warranty does not cover damages to **ANY** of our lifts due to accident, abuse, negligence, misuse, damage by improper use of chemicals, fading, ice damage, fire, rust beyond structural damage(does not cover cosmetic rust), exceeding the weight capacity for model purchased, failure to install or to assemble the product in accordance with the installation and assembly instructions, normal wear and tear from day to day use, not maintained properly, if unit is altered or repaired without written approval of Global Lift Corp – All Warranties are Void.*

To commence the warranty claim process of a Global Lift Corp product, in writing provide place of purchase along with the product name and description, date of installation and a detailed description of the defect, along with a photo of the entire product and claimed defect. Prior to a 30 day period

after receiving the written warranty claim by Global Lift Corp and barring any unforeseen delays the claimant will be notified of Global Lift Corp's decision regarding the claim.

If the request made by Global Lift Corp for the product to be returned to its factory or distributor of choice for inspection and/or repair, purchaser will be liable for "Freight Prepaid". Global Lift Corp at its option will replace or repair the defective item and deliver the repaired product or replacement to the buyer of the product, freight prepaid by the purchaser to the destination on file in regards to the original order. Parts and Products returned for replacement to Global Lift Corp shall remain the property of Global Lift Corp under this limited warranty.

A new warranty period shall not be established for any repaired or replaced products. Replaced or repaired products will remain under warranty only for the remainder of the original warranty period for the original product purchased. No person or organization is authorized to make any other specific or implied warranties on behalf of Global Lift Corp.

THE WARRANTIES ARE IN LIEU OF ALL OTHER WARRANTIES, EXPRESSED OR IMPLIED, WHICH ARE HEREBY DISCLAIMED AND EXCLUDED, INCLUDING WITHOUT LIMITATION ANY WARRANTY OF MERCHANTABILITY OR FITNESS FOR A PARTICULAR PURPOSE OR USE.

IN NO EVENT SHALL GLOBAL LIFT CORP BE LIABLE FOR ANY INCIDENTAL, CONSEQUENTIAL, INDIRECT, SPECIAL EXEMPLARY OR PUNITIVE DAMAGES OR LOST PROFITS FROM ANY BREACH OF THIS LIMITED WARRANTY. THE SOLE AND EXCLUSIVE REMEDY OF THIS WARRANTY IN REGARDS TO GLOBAL LIFT CORP'S PRODUCT SHALL BE LIMITED TO REPLACEMENT OR REPAIR AT A GLOBAL LIFT CORP'S FACILITY OR A DULY APPOINTED DISTRIBUTOR'S LOCATION OR AT A GLOBAL LIFT CORP'S DESIGNATED LOCATION. IN NO EVENT SHALL GLOBAL LIFT CORP LIABILITY EXCEED THE ENTIRE AMOUNT PAID TO GLOBAL LIFT CORP BY THE ORIGINAL PURCHASER IN REGARDS TO THE DEFECTIVE OR FAILED PRODUCT.

NO REPRESENTATIVE OF GLOBAL LIFT CORP SUCH AS AGENTS, DISTRIBUTORS AND DEALERS HAS THE AUTHORITY TO ALTER IN ANY FASHION THE TERMS OF THIS WARRANTY AND GLOBAL LIFT CORP IS "NOT" RESPONSIBLE FOR REPRESENTATION, UNDERTAKING OR WARRANTY MADE BY ANY OTHER PERSON BEYOND THE WARRANTIES EXPRESSED SET FORTH IN THIS WARRANTY.

Warranty Procedure

Warranty Claims shall be submitted to Global Lift Corporation by the distributor which originated the sale with Global Lift Corporation or directly to Global Lift Corporation.

All RGA (Return Goods Authorization) documents shall be requested by and issued only to the distributor which originated the sale or directly to Global Lift Corporation.

Global Lift Corporation shall determine warranty coverage validation and replacement parts or repair, which were directed to the distributor which originated the sale or that are initiated directly with Global Lift Corporation.

Warranty claims received from end users by Global Lift Corporation shall be re-directed to the distributor which originated the sale with Global Lift Corporation or processed directly by Global Lift Corporation.



**GLOBAL LIFT CORP
WARRANTY REGISTRATION
PURCHASED BY:**

Company

Name: _____ Contact: _____

City: _____ State: _____ Zip: _____

Phone: (____) _____

DEALER:

Name: _____ Phone Number _____

City: _____ State: _____ Zip: _____

Phone: (____) _____

Model: _____ Serial Number: _____

Color: _____ Purchase Price: \$ _____ Date Purchased: _____

I have read and I accept the warranty terms.

Signature: _____ Date: _____

This card must be completed and returned to Global Lift Corp within 30 days of purchase date to assure coverage.

Please mail to: Global Lift Corp, 684 N Port Crescent Suite C, Bad Axe, MI 48413

SUPERIOR SERIES LIFT NEW CONSTRUCTION & SAW CUT SLEEVE ANCHORING METHOD INSTALLATION MANUAL



FEB 2012

Superior New Construction/Saw Cut
Anchor



SUPERIOR SERIES SLEEVE ANCHORING SYSTEM INSTALLATION

PARTS LIST

- ✓ 1 - Anchor Sleeve w/ Base
- ✓ 1 - Binding screw
- ✓ 1 - Plastic Cap

ANCHORING SLEEVE, BASE PLATE & BINDING SCREW Superior Series



FEB 2012

Superior New Construction/Saw Cut
Anchor



ADA GUIDELINES FOR POOL LIFT PLACEMENT

- Pool Lift Location. Pool lifts shall be located where the water level does not exceed 48 inches (1220 mm).
Seat Location. In the raised position, the centerline of the seat shall be located over the deck and 16 inches (405 mm) minimum from the edge of the pool. The deck surface between the centerline of the seat and the pool edge shall have a slope not steeper than 1:48.

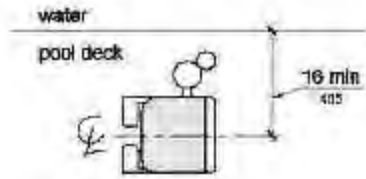

- Clear Deck Space. On the side of the seat opposite the water, a clear deck space shall be provided parallel with the seat. The space shall be 36 inches (915 mm) wide minimum and shall extend forward 48 inches (1220 mm) minimum from a line located 12 inches (305 mm) behind the rear edge of the seat. The clear deck space shall have a slope not steeper than 1:48.

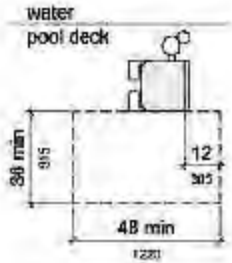

- Submerged Depth. The lift shall be designed so that the seat will submerge to a water depth of 18 inches (455 mm) minimum below the stationary water level.

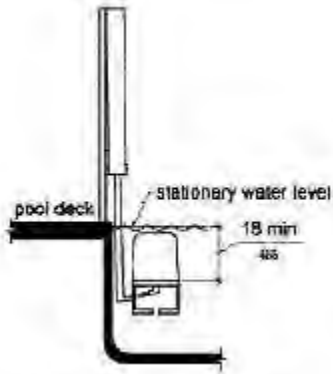

SUPERIOR SERIES – SLEEVE ANCHORING SYSTEM

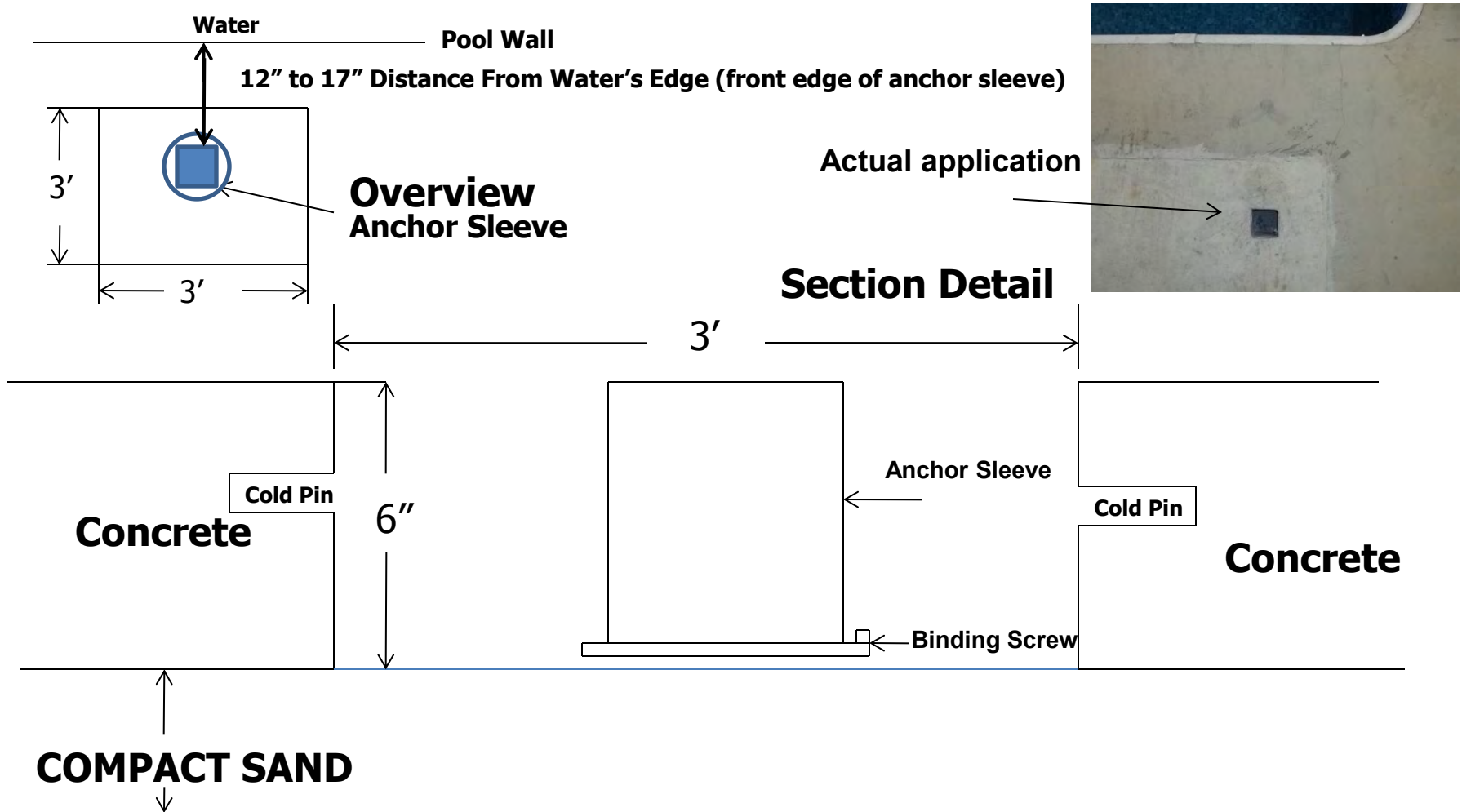

Front of Anchor Sleeve must be 12" to 17" from the water's edge. Optimal placement is 14"
Connect copper wire to the binding screw and then to your bonding grid
Cold Pin's should be 1/2" rebar 6" to 8" long
NOTE: Make sure your anchor sleeve is level and square with your pool's edge.

Step 1: Determine the location for installation (Make sure all ADA requirements are met).

*****NOTE: The installation of Global Lift Corp's anchor system's are a guideline of minimum requirements. In some states or municipalities they may require additional steps due to their local codes or ordinances.*****

Step 2: Make sure that all the parts are present (Refer to the parts list)

- ✓ 1 - Anchor Sleeve w/ Base
- ✓ 1 - Binding Screw
- ✓ 1 - Plastic Cap

Step 3: At the determined location for installation, chalk out a 3' X 3' area prior to cutting out the concrete. (Refer to overview, the front end of the Anchor Sleeve must be 12" to 17" from the water's edge and 6" deep). New Construction, the concrete must be 6" deep with a 1/2" reinforcing rod, minimum of an 18" grid.

NOTE: Make sure that all local codes and ordinances are met.

Step 4: Once the 3' X 3' area is cut out, make sure you drill in the inner wall of all 4 sides of the area (refer to the section detail) for the purpose of cold pinning the new concrete to the old concrete. Use 1/2" rebar, 6" to 8" in length.

Step 5: Place the Anchor Sleeve in the cut out area, make sure that the front of the Anchor Sleeve is **12" to 17"** from the **water's edge**. (refer to overview) A key element is to make sure that the Anchor Sleeve is level and square with the pool so that your Superior Series Lift sits properly on the deck.

Step 6: Bonding the unit – The binding screw is supplied with the Anchor Sleeve locate the binding screw, connect the binding screw to the bonding grid.

NOTE: Make sure that all local codes and ordinances are met.

Step 7: Pouring your concrete, (make sure you cover the hole on your anchor sleeve with the plastic cap provided, **so you don't get concrete in the sleeve**) a minimum of 4,000 psi concrete with reinforcing rod. Also make sure that the top of the anchor sleeve is flush with the deck. Before you install your lift make sure you let the concrete set up for 48 hours.

Step 8: **After the concrete has set for 48 hours, now it's time to install your lift.** Place your Superior Series Lift over the anchor sleeve, once you have completed the installation, please refer to User's Manual for a safe operation.

SUPERIOR SERIES LIFT RETRO-FIT SLEEVE ANCHORING METHOD INSTALLATION MANUAL



S & P Retro Fit Sleeve Anchoring
Method



RETRO-FIT SLEEVE ANCHORING SYSTEM SUPERIOR SERIES LIFT

PACKING LIST

- 1 – Anchor Sleeve w/ Base
- 1 – Binding Screw
- 1 – Plastic Cap

ADA GUIDELINES FOR POOL LIFT PLACEMENT

- Pool Lift Location. Pool lifts shall be located where the water level does not exceed 48 inches (1220 mm).
Seat Location. In the raised position, the centerline of the seat shall be located over the deck and 16 inches (405 mm) minimum from the edge of the pool. The deck surface between the centerline of the seat and the pool edge shall have a slope not steeper than 1:48.

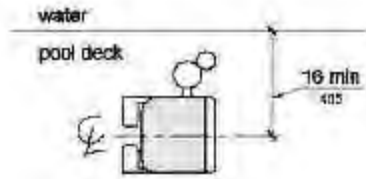

- Clear Deck Space. On the side of the seat opposite the water, a clear deck space shall be provided parallel with the seat. The space shall be 36 inches (915 mm) wide minimum and shall extend forward 48 inches (1220 mm) minimum from a line located 12 inches (305 mm) behind the rear edge of the seat. The clear deck space shall have a slope not steeper than 1:48.

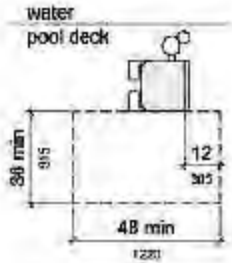

- Submerged Depth. The lift shall be designed so that the seat will submerge to a water depth of 18 inches (455 mm) minimum below the stationary water level.

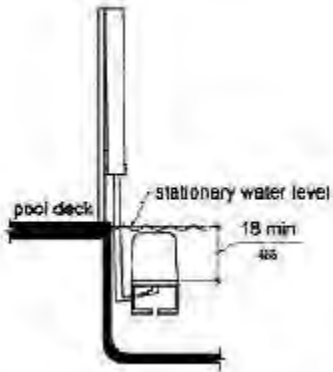

S & P Retro Fit Sleeve Anchoring
Method



Water's edge – Must be 12" to 17" in distance from the front of the anchor sleeve



Picture A

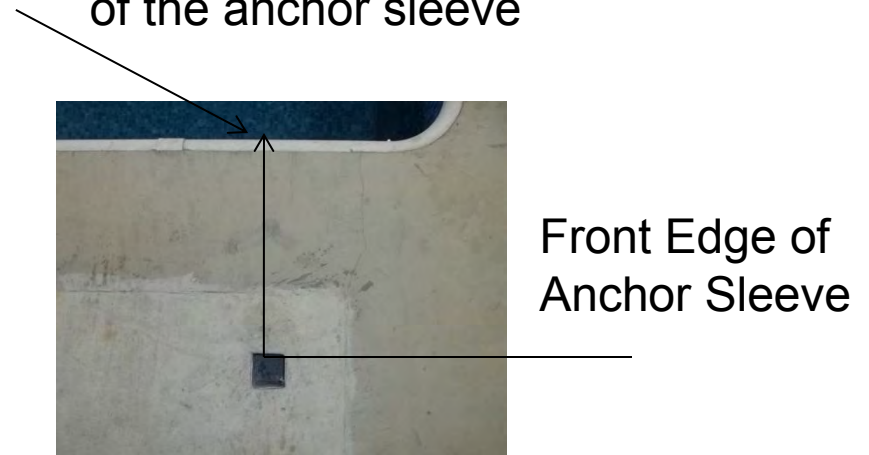

Picture B

STEP 1: Locate the retro-fit anchoring sleeve (as shown above) picture A

- Once you determine where your lift is going to be located at your pool, place the anchor sleeve down so you can mark a circle around the base on the concrete where you will need to drill the hole. NOTE: From the water's edge to the front end of the Anchor sleeve must 12" to 17". See picture B

*****NOTE:** The installation of Global Lift Corp's anchor system's are a guideline of minimum requirements. In some states or municipalities they may require additional steps due to their local codes or ordinances.***



Picture A

Front edge of anchor sleeve

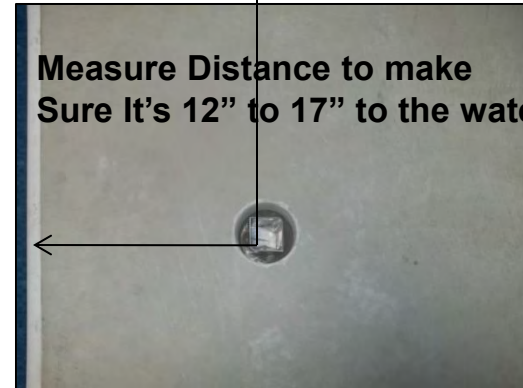

Picture B

Step 2: You will need a 5" diameter core drilling bit.

- Make sure you have accurately marked your hole location to be drilled. After drilling your hole (picture A), it must be 6" deep and flat on the bottom of the hole (shown above). Also Double check your measurements, they should be: Place your anchor sleeve in the hole and make sure the front edge of the sleeve is 12" to 17" from the pools edge. Along with connecting to the bonding grid , ensure all local codes and ordinances are met. (picture B)



STEP 3 : Cementing the anchor sleeve in the concrete. Make sure your anchor is level and Square.

- You will need 10 lbs of Quick dry Anchoring Cement (Commercial Grade Quikrete Exterior Use Anchoring Cement) to complete the installation. You can purchase at any hardware store in your area. Read the label and follow manufacturer's instructions.
- Start pouring into the hole evenly until you fill it up, make sure not to overfill the hole so that it does not create more work to scrap excess concrete off.
- Let the concrete set for 24hrs, sand the area with a sand stone to smooth the finish.
- Make sure the anchor sleeve is flush with the concrete.
- You are now ready to install your Superior Series lift.

Fixed Anchor Superior Series



Once you have completed the installation of your lift, locate the 3/8 bolt and secure it in the pre-drilled hole inside the anchor sleeve and tighten.

Your lift is now ready to be used.

Optional Fixed Drop In Anchor Instructions for

Superior Series



Pre-drilled hole on the
base of S-350 & P-375 Lift

After you have installed your square anchor, You are ready to install the optional fixed drop in anchor.

Position the lift into square anchor.

Locate the pre-drilled hole on the base of the lift.

Now mark the concrete so you will know where to drill.

Remove the lift from the anchor.

You will need a 7/8" rock carbide drilling bit.

- Make sure you have accurately marked the hole location to be drilled. After drilling your hole it must be 2 1/2" deep
- Clean hole with pressurized air or vacuum.
- Administer Epoxy into the hole prior to inserting the drop in anchor.
- Drive the anchor flush with the surface of concrete .
- Expand the anchor with the setting tool (provided). Anchor is properly expanded when shoulder of the setting tool is flush with the top of the anchor.
- Position the lift back on the square anchor.
- Insert drop in anchor bolt and tighten.
- Fix your square anchor in place with the 3/8" bolt inside the anchor sleeve.



Setting tool shown



3/8" bolt inside anchor sleeve

GLOBAL LIFT CORP CUSTOM SEAT INSTALLATION MANUAL C & S Series Lifts



GLOBAL LIFT CORP

CUSTOM SEAT INSTALLATION MANUAL

PARTS LIST

- 1 - Custom Seat
- 1 - Foot Rest
- 2 – Arm Rests
- 1 - Seat Belt & Buckle
- 1 – ½” x 2 ¾” Securing Bolt
- 3 – 5/16 x 3” Attaching Pin with lock nut
- 1 – 5/16 x 2” Foot Rest attaching bolt w/ nut
- 1 – 2” Round cap
- 1 – 1” Round cap



INSTALLATION STEPS



Picture A

Step 1:

Unpack your custom seat (picture A). Loose Items will consist of:

- Foot Rest and Tube
- $\frac{1}{2}$ " x 3" Bolt w/ lock nut
- $\frac{5}{16}$ " x 2 $\frac{3}{4}$ " Bolt with Lock nut

INSTALLATION STEPS



Picture A



Picture B

Step 2:

Align your custom seat (Picture A), slide the lower seat tube into the upper Seat tube.

Step 3:

Once you have the seat in place, take your $\frac{1}{2}$ " x 3" bolt and slide it through the pre-drilled Holes (Picture B). Once you have inserted the bolt all the way through, apply the locking nut (supplied) and tighten down.

INSTALLATION STEPS



Step 4:
Locate the 5/16 x 3" securing bolt (supplied), insert the bolt through the pre-drilled Seat and tube holes (As shown Above). Once you have the bolt inserted, secure the installation With the lock nut that is provided and tighten down.



INSTALLATION STEPS

FOOT REST



Picture A



Picture B

Step 5:

In picture A, slide the foot tube through the foot rest sleeve and line the hole to the Slot. In picture B, locate the 5/16" x 2" bolt and insert into the pre-drilled holes to secure the foot rest to the lift. Place the lock nut on the bolt and tighten down. Once that is complete, you are ready to enjoy your Global Lift Corp pool lift.

REV.	DESCRIPTION	DATE	APVD.
------	-------------	------	-------

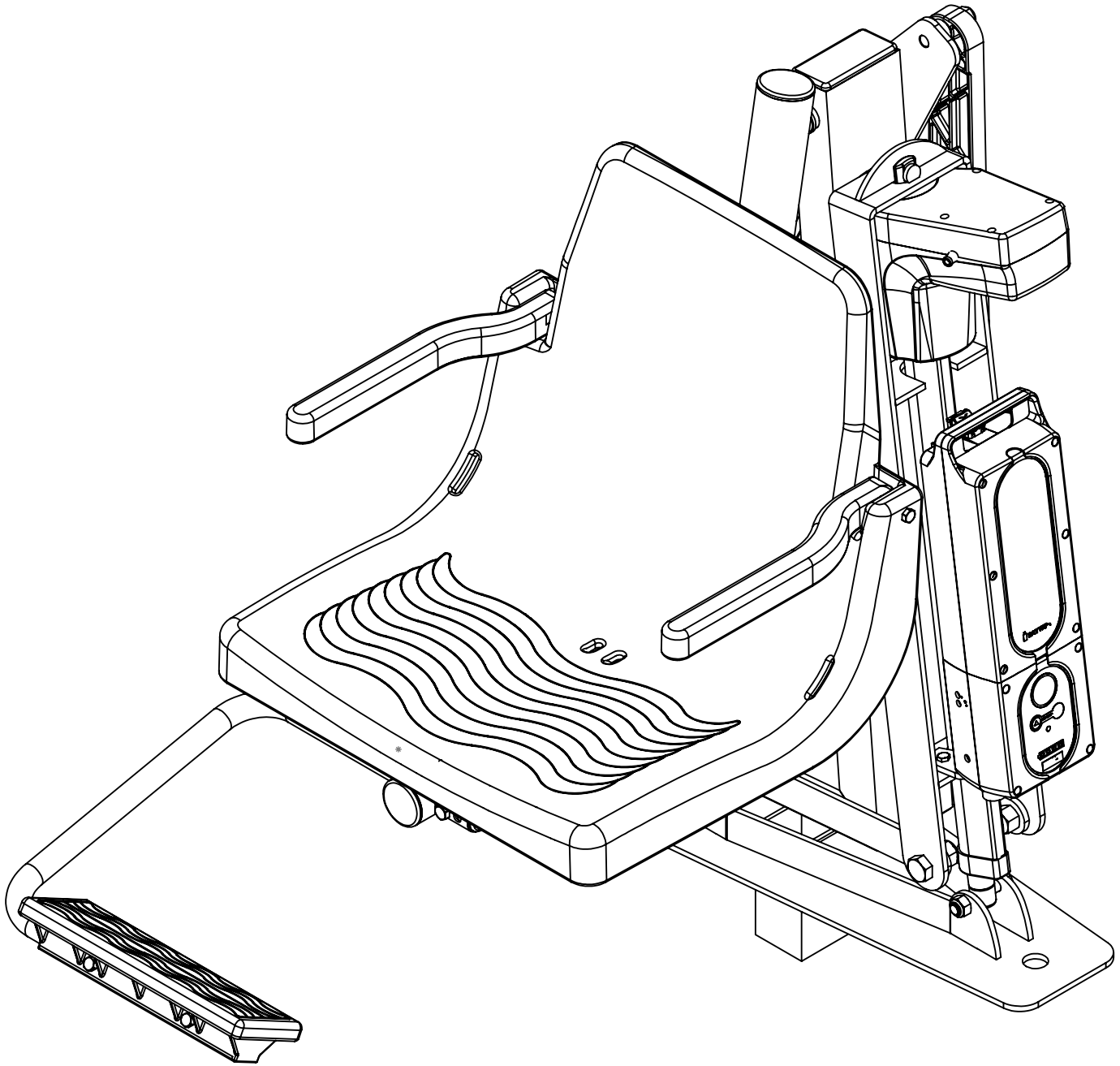

MATERIAL:

SCALE: 1:6	REV: 100	DATE: 12/13/2012	DWR: B.E.
WEIGHT: LBS		MACH WEIGHT: LBS	
DO NOT SCALE DRAWING UNLESS OTHERWISE SPECIFIED DIMENSIONS ARE IN INCHES TOLERANCES ARE:		APVD BY: J.I.	

DO NOT SCALE DRAWING
UNLESS OTHERWISE SPECIFIED
DIMENSIONS ARE IN INCHES
TOLERANCES ARE:

X. = ±.125
XX. = ±.062
XXX. = ±.031

FRACTIONAL DIMENSIONS ±.125
FILLET RADIUS .000 THRU +.094
HOLES .000 THRU .015
ANGLES ± 1 DEGREE

PROPRIETARY AND CONFIDENTIAL

THE INFORMATION CONTAINED IN THIS DRAWING IS THE SOLE
PROPERTY OF Global Lift Corporation. ANY REPRODUCTION IN
PART OR AS A WHOLE WITHOUT THE WRITTEN PERMISSION OF
Global Lift Corp. IS PROHIBITED.



684 N. Port Crescent, Suite C
Bad Axe, MI 48413

TITLE:	S-350
DWG. NO.	ASSEMBLY MANUAL

REV.	DESCRIPTION	DATE	APVD.
------	-------------	------	-------

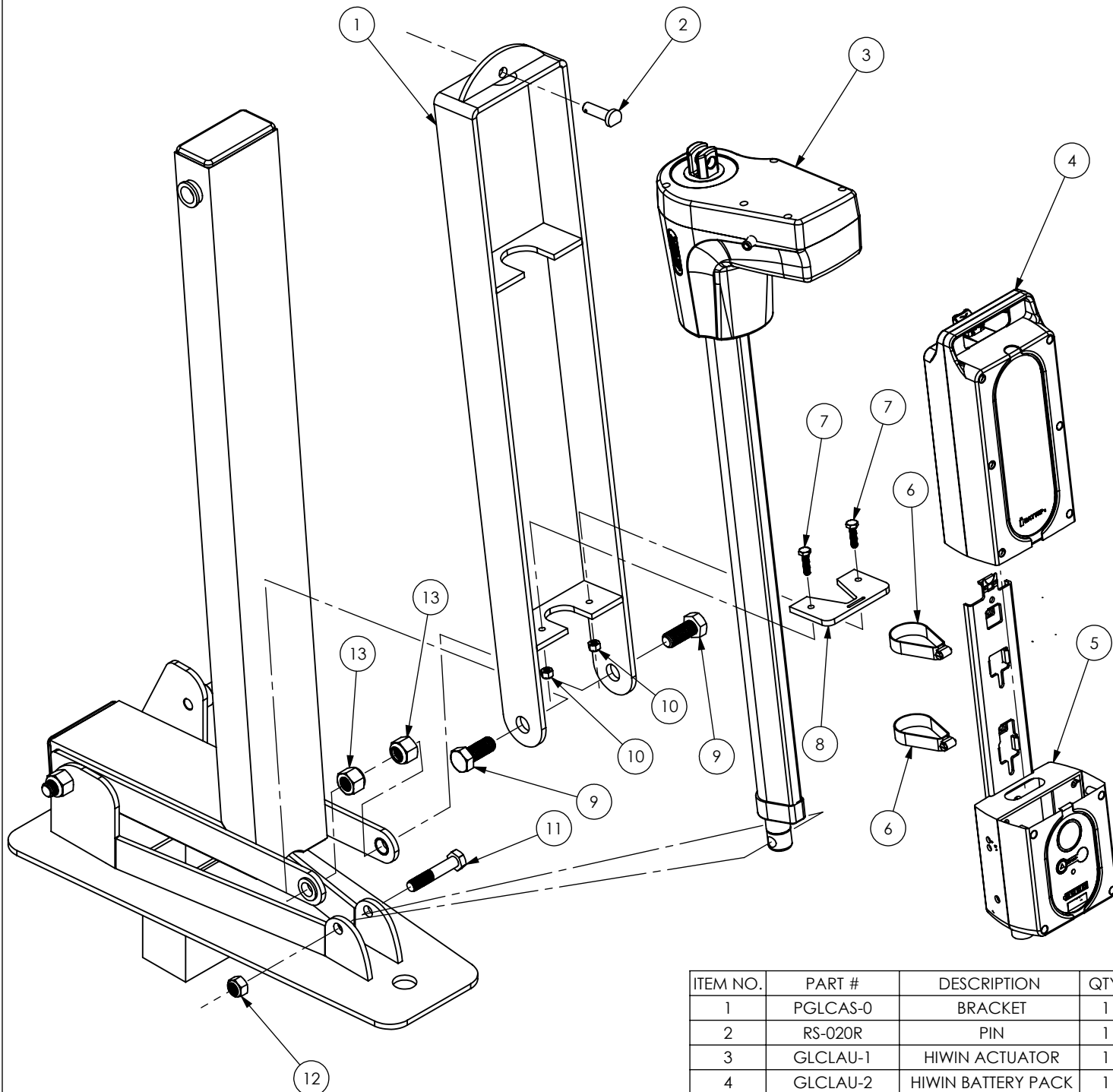

ITEM NO.	PART #	DESCRIPTION	QTY.
1	PGLCAS-0	BRACKET	1
2	RS-020R	PIN	1
3	GLCLAU-1	HIWIN ACTUATOR	1
4	GLCLAU-2	HIWIN BATTERY PACK	1
5	GLCLAU-5	HIWIN CONTROL BOX	1
6	HCLAMP-0	HOSE CLAMP	2
7	BOLT25-20-1	BOLT	2
8	PGLCAS-5	BRACKET	1
9	BOLT625-11-1.5	BOLT	2
10	NUT25-20	NUT	2
11	BOLT-M12-65	BOLT	1
12	NUT-M12	NUT	2
13	NUT625-11	NUT	2

MATERIAL:

SCALE: 1:6	REV: 100	DATE: 12/13/2012	DWR: B.E.
WEIGHT: LBS	MACH WEIGHT: LBS	APVD BY: J.I.	

DO NOT SCALE DRAWING
UNLESS OTHERWISE SPECIFIED
DIMENSIONS ARE IN INCHES
TOLERANCES ARE:
X. = ±.125
XX. = ±.062
XXX. = ±.031
FRACTIONAL DIMENSIONS ±.125
FILLET RADIUS .000 THRU +.094
HOLES .000 THRU .015
ANGLES ± 1 DEGREE

PROPRIETARY AND CONFIDENTIAL
THE INFORMATION CONTAINED IN THIS DRAWING IS THE SOLE
PROPERTY OF Global Lift Corporation. ANY REPRODUCTION IN
PART OR AS A WHOLE WITHOUT THE WRITTEN PERMISSION OF
Global Lift Corp. IS PROHIBITED.



684 N. Port Crescent, Suite C
Bad Axe, MI 48413

TITLE:	S-350 BATTERY, ACTUATOR & ACTUATOR BRACKET
DWG. NO.	ASSEMBLY

ITEM NO.	PART #	DESCRIPTION	QTY.
1	PLASCAP-5	PLASTIC CAP	2
2	BUSH75-5	BUSHING	2
3	SGLCMB-0	MAIN BEAM	1
4	BUSH625-344	BUSHING	2
5	BUSH625-625	BUSHING	2
6	BOLT625-11-6.5	BOLT	1
7	PGLCBP-0	BASE PLATE	1
8	NUT625-11	NUT	1

REV.	DESCRIPTION	DATE	APVD.
------	-------------	------	-------

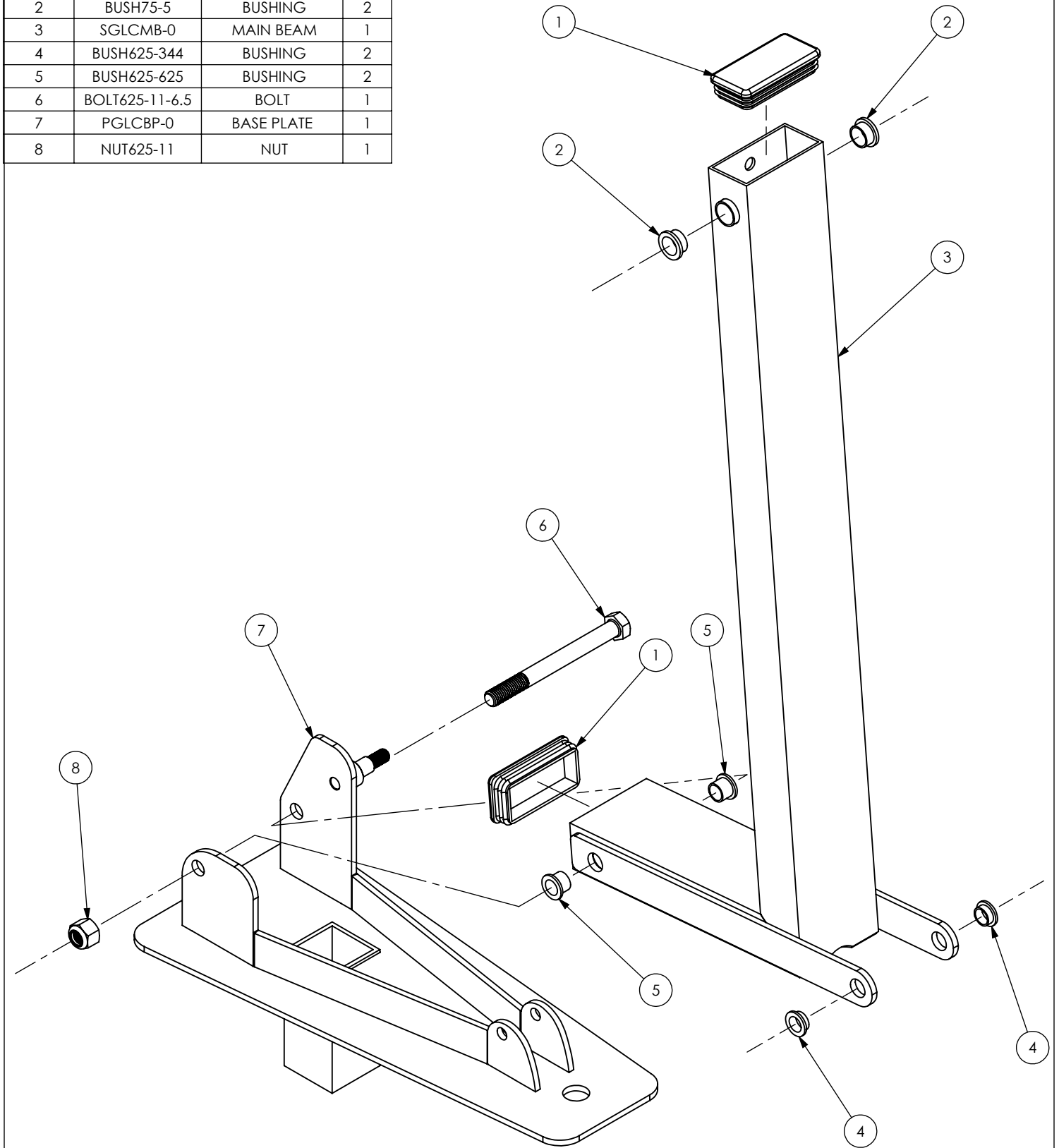

MATERIAL:

SCALE: 1:5	REV: 100	DATE: 12/13/2012	DWR: B.E.
WEIGHT: LBS	MACH WEIGHT: LBS	APVD BY: J.I.	

DO NOT SCALE DRAWING
UNLESS OTHERWISE SPECIFIED
DIMENSIONS ARE IN INCHES
TOLERANCES ARE:

X. = ±.125
XX. = ±.062
XXX. = ±.031

FRACTIONAL DIMENSIONS ±.125
FILLET RADIUS .000 THRU +.094
HOLES .000 THRU .015
ANGLES ± 1 DEGREE

PROPRIETARY AND CONFIDENTIAL

THE INFORMATION CONTAINED IN THIS DRAWING IS THE SOLE
PROPERTY OF Global Lift Corporation. ANY REPRODUCTION IN
PART OR AS A WHOLE WITHOUT THE WRITTEN PERMISSION OF
Global Lift Corp. IS PROHIBITED.



684 N. Port Crescent, Suite C
Bad Axe, MI 48413

TITLE: S-350
MAIN BEAM
TO
BASE PLATE

DWG. NO. ASSEMBLY

8 7 6 5 4 3 2 1

NOTES

REV.	DESCRIPTION	DATE	APVD.
------	-------------	------	-------

D

D

C

C

B

B

A

A

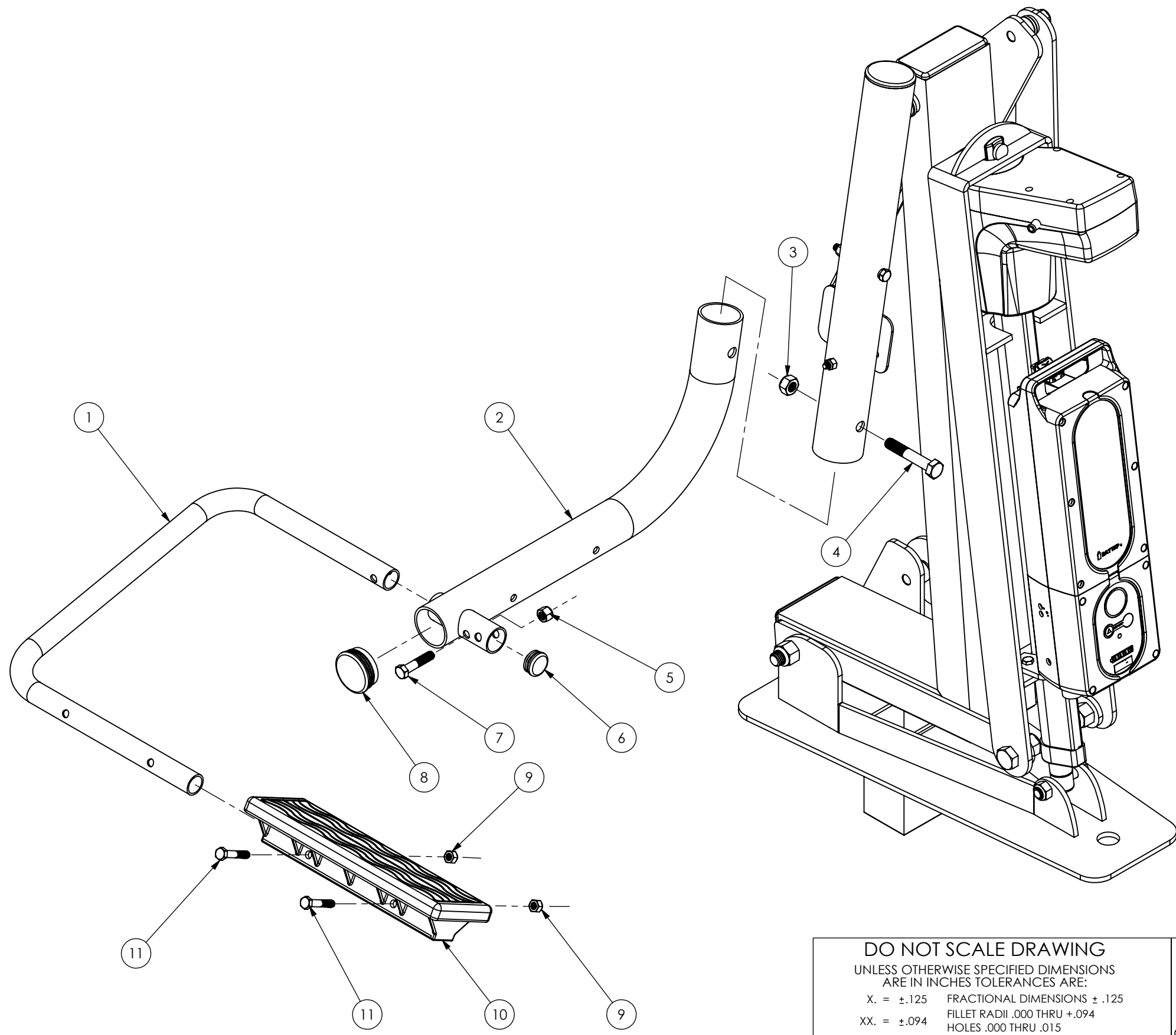

ITEM NO.	PART #	DESCRIPTION	QTY.
1	GLCSEATB-7	FOOT REST TUBE	1
2	GLCSEATB-BOTTOM	SEAT SUPPORT BOTTOM	1
3	NUT-M12	NUT	1
4	BOLT-M12-70	BOLT	1
5	NUT375-16-2	NUT	1
6	PLASCAP-1	PLASTIC CAP	1
7	BOLT375-16-1.75	BOLT	1
8	PLASCAP-2	PLASTIC CAP	1
9	NUT313-18	NUT	2
10	GLCSEATB-9	FOOT REST	1
11	BOLT313-18-1.75	BOLT	2

DO NOT SCALE DRAWING
 UNLESS OTHERWISE SPECIFIED DIMENSIONS ARE IN INCHES TOLERANCES ARE:
 X. = ±.125 FRACTIONAL DIMENSIONS ± .125
 XX. = ±.094 FILLET RADII .000 THRU +.094
 XXX. = ±.062 HOLES .000 THRU .015
 ANGLES ± 1°



684 N. Port Crescent, Suite C
 Bad Axe, MI 48413

TITLE:
**S-350
 FOOT REST TUBE, SEAT TUBE
 & FOOT REST INSTALLATION**

DWG. NO. **ASSEMBLY**

PROPRIETARY AND CONFIDENTIAL
 THE INFORMATION CONTAINED IN THIS DRAWING IS THE SOLE PROPERTY OF Global Lift Corporation. ANY REPRODUCTION IN PART OR AS A WHOLE WITHOUT THE PERMISSION OF Global Lift Corp. IS PROHIBITED.

SCALE: 1:5	DATE: 12/14/2012	DWR: B.E.	REV 100
WEIGHT: LBS	MACH WEIGHT: LBS	APVD. BY: J.I.	

MATERIAL: NOTED

8 7 6 5 4 3 2 1

REV.	DESCRIPTION	DATE	APVD.
------	-------------	------	-------

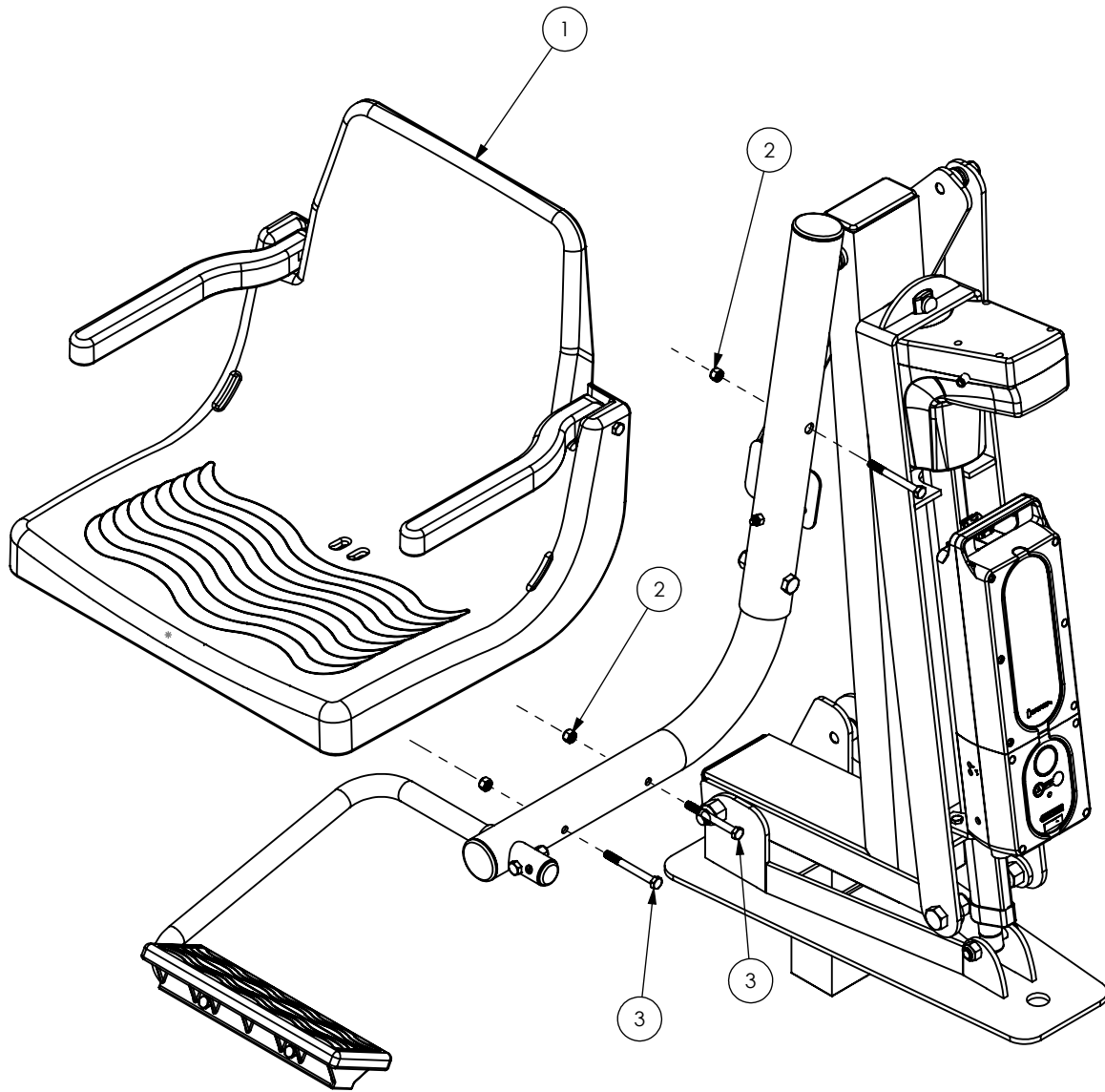

ITEM NO.	PART #	DESCRIPTION	QTY.
1	GLCSEATB-1	MOLDED PLASTIC SEAT	1
2	NUT313-18	NUT	3
3	BOLT313-18-3	BOLT	3

MATERIAL:

SCALE: 1:8	REV: 100	DATE: 12/14/2012	DWR: B.E.
WEIGHT: LBS	MACH WEIGHT: LBS	APVD BY: J.I.	

DO NOT SCALE DRAWING
UNLESS OTHERWISE SPECIFIED
DIMENSIONS ARE IN INCHES
TOLERANCES ARE:
X. = ±.125 FRACTIONAL DIMENSIONS ±.125
XX. = ±.062 FILLET RADIUS .000 THRU +.094
XXX. = ±.031 HOLES .000 THRU .015
ANGLES ± 1 DEGREE

PROPRIETARY AND CONFIDENTIAL
THE INFORMATION CONTAINED IN THIS DRAWING IS THE SOLE
PROPERTY OF Global Lift Corporation. ANY REPRODUCTION IN
PART OR AS A WHOLE WITHOUT THE WRITTEN PERMISSION OF
Global Lift Corp. IS PROHIBITED.



684 N. Port Crescent, Suite C
Bad Axe, MI 48413

TITLE:	S-350 SEAT TO LIFT
DWG. NO.	ASSEMBLY

REV.	DESCRIPTION	DATE	APVD.
------	-------------	------	-------

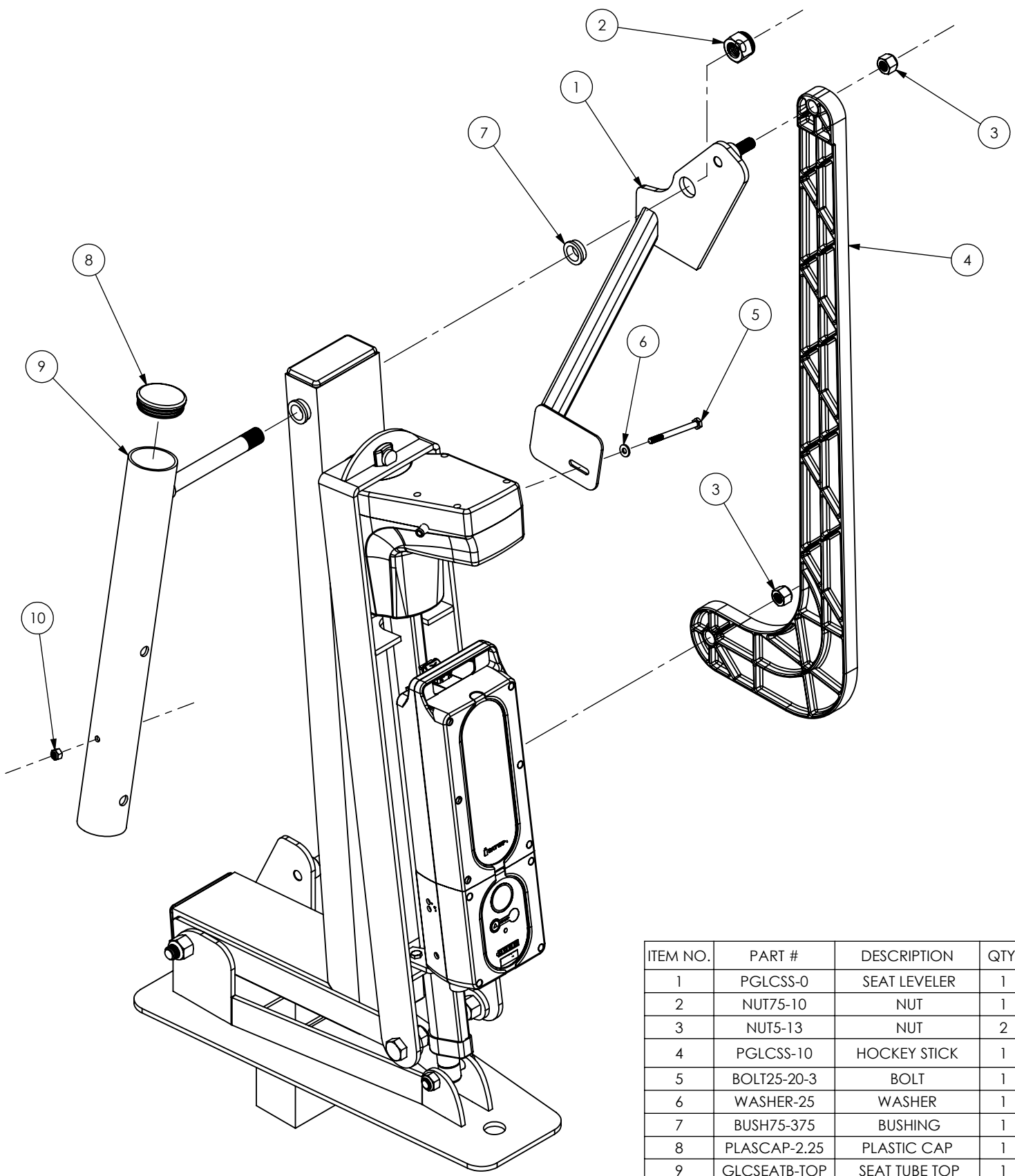

ITEM NO.	PART #	DESCRIPTION	QTY.
1	PGLCSS-0	SEAT LEVELER	1
2	NUT75-10	NUT	1
3	NUT5-13	NUT	2
4	PGLCSS-10	HOCKEY STICK	1
5	BOLT25-20-3	BOLT	1
6	WASHER-25	WASHER	1
7	BUSH75-375	BUSHING	1
8	PLASCAP-2.25	PLASTIC CAP	1
9	GLCSEATB-TOP	SEAT TUBE TOP	1
10	NUT25-20	NUT	1

MATERIAL:

SCALE: 1:6	REV: 100	DATE: 12/13/2012	DWR: B.E.
WEIGHT: LBS	MACH WEIGHT: LBS	APVD BY: J.I.	

DO NOT SCALE DRAWING
UNLESS OTHERWISE SPECIFIED
DIMENSIONS ARE IN INCHES
TOLERANCES ARE:
X. = ±.125
XX. = ±.062
XXX. = ±.031
FRACTIONAL DIMENSIONS ±.125
FILLET RADII .000 THRU +.094
HOLES .000 THRU .015
ANGLES ± 1 DEGREE

PROPRIETARY AND CONFIDENTIAL
THE INFORMATION CONTAINED IN THIS DRAWING IS THE SOLE
PROPERTY OF Global Lift Corporation. ANY REPRODUCTION IN
PART OR AS A WHOLE WITHOUT THE WRITTEN PERMISSION OF
Global Lift Corp. IS PROHIBITED.



684 N. Port Crescent, Suite C
Bad Axe, MI 48413

TITLE:	S-350 SEAT TUBE, Z-BRACKET & HOCKEY STICK
DWG. NO.	ASSEMBLY